

FORCEPACTM

By Aries Engineering Company, Inc.  MADE IN AMERICA

User Manual 2022-01

FP-100K



FP-50K



FP-20K



Table of contents

1.0	Introduction	3
1.1	Warranty	3
1.2	Safety symbols.....	3
2.0	Models and technical specifications.....	4
2.1	General Usage.....	4
2.2	Model FP-20k – Load button.....	4
2.3	Model FP-50k – Load button.....	5
2.4	Model FP-100k – Load button.....	6
3.0	Selecting and operating the loadcell.....	7
3.1	Load cell capacity	7
3.2	Operating the load cell.....	8
3.2.1.	Mounting guideline.....	8
4.0	Inspection of the load cell	9
4.1	Maintenance	9

1.0 Introduction

1.1 Warranty

This instrument is warranted against defects in workmanship, material and design for one (1) year from date of delivery to the extent that Aries Engineering Company will, at its sole option, repair or replace the instrument or any part thereof which is defective, provided, however, that this warranty shall not apply to instruments subjected to tampering, abuse, or exposed to highly corrosive conditions.

This warranty is voidable if the purchaser fails to follow any and all instructions, warnings or cautions in the instrument's User Manual.

If a manufacturing defect is found, Aries Engineering Company will replace or repair the instrument or replace any defective part thereof without charge; however, AEC's obligation hereunder does not include the cost of transportation, which must be owned by the customer. AEC assumes no responsibility for damage in transit, and any claims for such damage should be presented to the carrier by the purchaser.

Technical assistance

Please contact Aries Engineering Company/Service if you require technical assistance. 734-529-8855 or e-mail to service@hypercyl.com

1.2 Safety symbols

This manual contains a number of safety symbols designed to draw your attention to instructions, which must be followed when using the instrument, as well as any risks involved.



Warning

Conditions and actions that may compromise the safe use of the instrument and result in considerable personal or material damage.



Caution...

Conditions and actions that may compromise the safe use of the instrument and result in slight personal or material damage.



Note...

Special situations, which demand the user's attention.

2.0 Models and technical specifications

2.1 Type of measuring task



Aries Engineering Company's ForcePac is intended to be used on a singular bases to verify load exertion and it is not suggested to be a permanent fixture to any machine or process. In addition, the ForcePac is NOT designed for high impact loads. High impact loading may damage the load button and create an unsafe environment for the operator.



2.2 Model FP-20K – (20,000 lb. Capacity Load button)

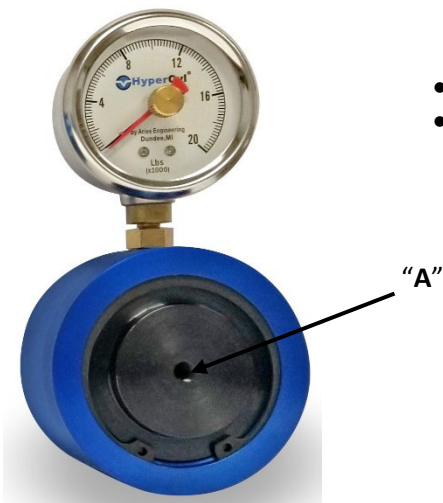

- The FP-20K gauge dial reads **in increments of 200 lbs.**
- "A" - 5/16-18 threaded lift hole (Eyebolt not included)



Resettable MAX POINTER.

DIMENSIONAL INFORMATION:

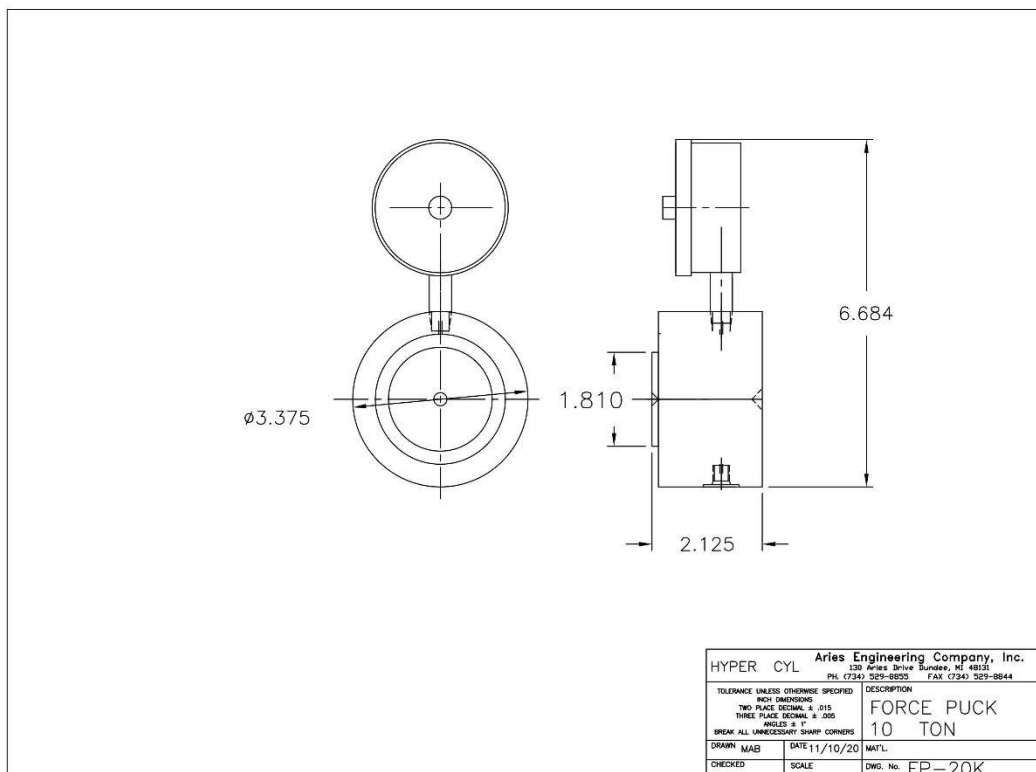

Models and technical specifications

2.3 Model FP-50K – (50,000 lb. Capacity Load button)

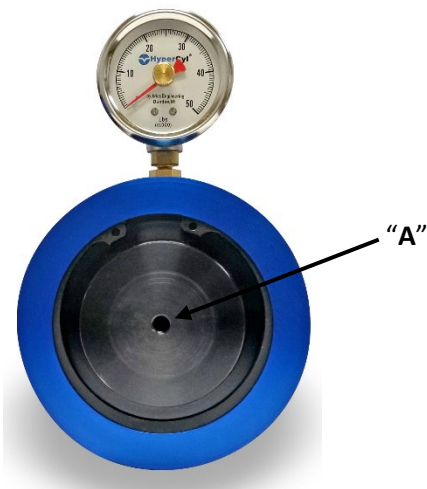

- The FP-50K gauge dial reads in **increments of 1000 lbs.**
- **"A"**- 3/8-16 threaded lift hole (Eyebolt not included)



Resettable MAX POINTER.

DIMENSIONAL INFORMATION:

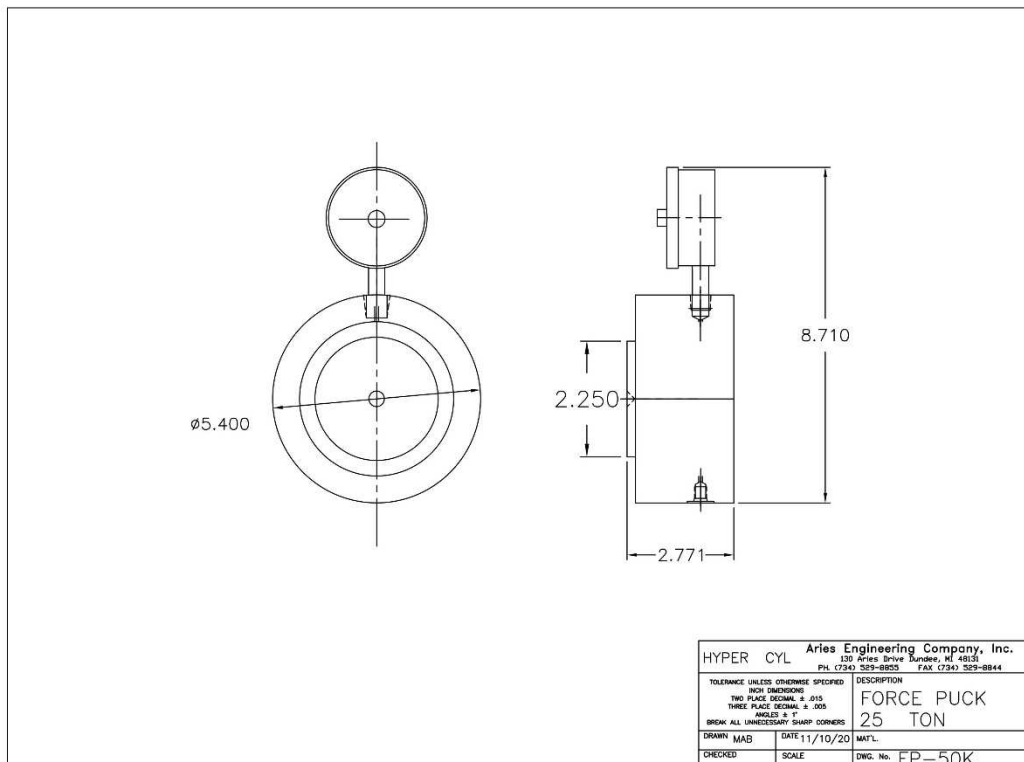

Models and technical specifications

2.4 Model FP-100K – (100,000 lb. Capacity Load button)

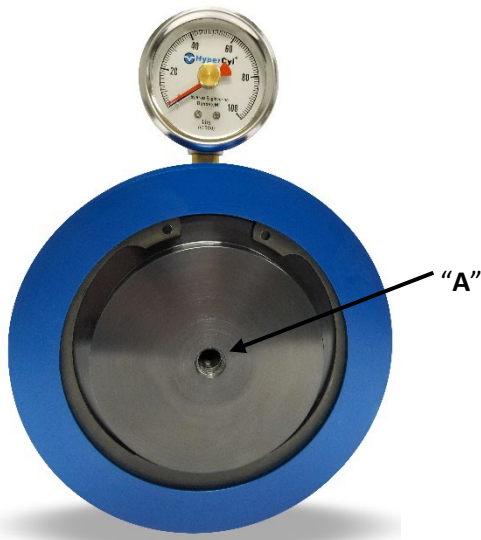

- The FP-100K gauge dial reads in **increments of 1000 lbs.**
- “A”- 1/2-13 threaded lift hole (Eyebolt not included)

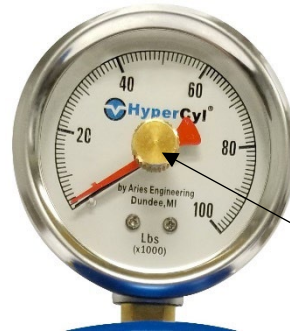

Resettable MAX POINTER.

DIMENSIONAL INFORMATION:

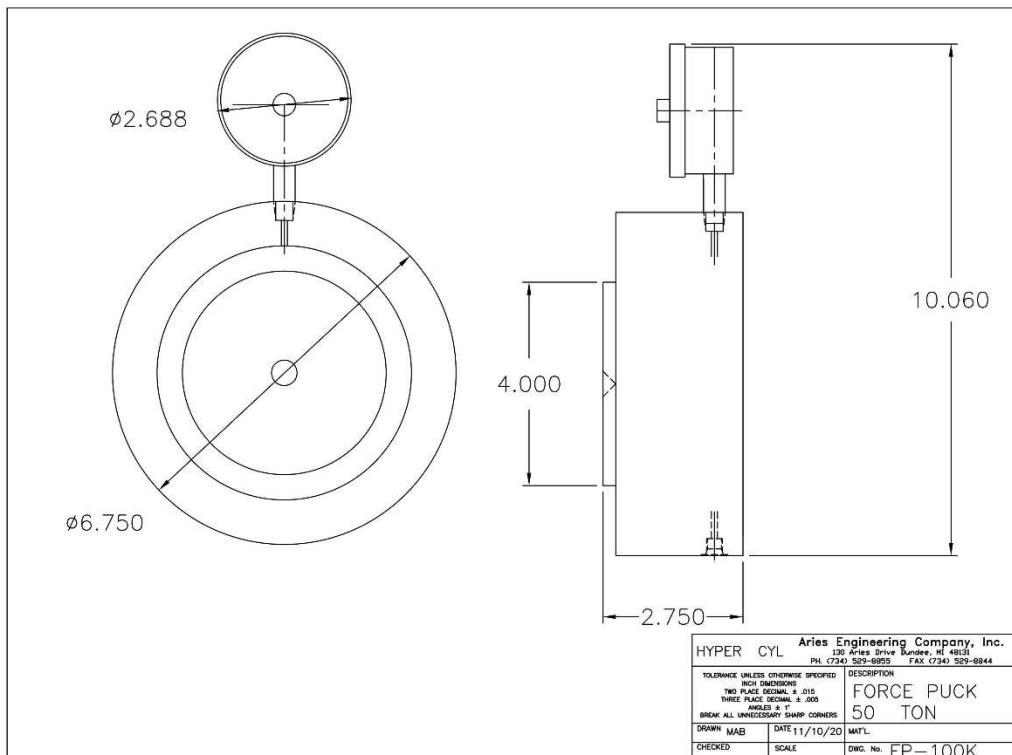

3.0 Selecting and operating the load cell

The ForcePac uses a conventional piston and cylinder arrangement.

All ForcePac Load Cell bodies are made from 6061 T-6 aluminum surface finished in Blue anodized. The Piston is made from 1018 mild steel surface finished in Black Oxide. The gauge is stainless steel.

The ForcePac is pre-filled with oil from the factory. When the load is applied on the piston, the movement of the piston results in an increase of oil pressure that in turn produces a change in the pressure on the gauge, which has been manufactured in conjunction for the relative bore size.

Because this sensor has no electrical components, it is ideal for use in hazardous areas.

3.1 ForcePac capacity

In order to reach the best performance of the measuring system it is very important to select a load cell with the correct capacity.

The following guidelines should be considered when selecting a load cell for a specific task:

- All load cells selected must be of the same capacity when using multiple Forcepacs.
- Estimate the dead weight, including all piping, pumps, agitators, insulation and heating fluid of the installation or device to be measured.
- Add the max. live weight or force of the product to be measured to the dead weight. This is the gross weight or force of the installation/device and contents.
- Divide the gross weight by the number of legs or support points. This is the nominal weight which will be carried by each ForcePac.
- Select a ForcePac with a capacity somewhat greater than the nominal weight. The following should be considered when determining how much greater the load cell capacity should be:



- Is your dead weight accurate?
- Will the load be evenly distributed on all cells?
- Is the installation/machine fitted with an agitator or subjected to shock loading?
- Is overload a risk and what excess force capacity should be added to compensate?
- Will the installation/device be subjected to wind or seismic loading?

3.2 Operating the load cell



Warning

Misuse or improper fixturing/staging of the ForcePac presents a liability to both operator and machine.



Caution...

- Be careful not to apply excessive pressure on or mount anything in contact with the button area.
- Load must be applied uniformly on entire loading surface.
- Any tampering or removal of snap ring will void warranty.

3.2.1. Mounting guideline

	1. Make sure that the load cell is placed on a flat and even surface.		
	2. Maintain a clean surface at all times.		
	3. The support fixture should contact the largest surface possible.		
	4. Side load may damage the sensor.		
	5. The load fixture must contact the top inner ring only.		
	6. The load fixture should be applied in line.		
	7. The load fixture should be applied on the center of the button.		

4.0 Inspection of the load cell

Periodically the load cell should be inspected for potential problems. The schedule for periodic maintenance is up to each customer's in-house schedules and should be adjusted based on the environment, usage, chemicals (including water), abrasives and other factors that may encounter the Force-Pac. Investigate for the following:

- rust
- corrosion
- oxidation
- metal distortion
- cracks
- metal rippling
- abrasions in the metal

If any of the above problems are detected, the load cell must be removed and sent to AEC for evaluation. Please contact service@hypercyl.com or call 734-529-8855.